

Technical Manual
WATER SOFTENER



Models: **H2O-CS-ECO**

TABLE OF CONTENT

Table of content.....	Page 2
Warning & Safety instructions	Page 3
Operating conditions & Requirements	Page 4
Installation	Page 5
Commissioning.....	Page 6
Electronic control panel.....	Page 7
Maintenance	Page 11
Hydraulic flow diagram	Page 12
Troubleshooting.....	Page 14
Electrical wiring diagram.....	Page 16
Default configuration parameter settings	Page 17
Exploded view - System	Page 18
Exploded view - Valve body assembly	Page 20
Exploded view - Valve head & Timer assembly	Page 22
Technical data	Page 23

WARNING & SAFETY INSTRUCTIONS

- Before you begin the installation of the appliance, we advise you read and carefully follow the instructions contained in this manual. It contains important information about safety, installation, use and maintenance of the product. The actual system that you have received, may differ from the pictures/illustrations/descriptions in this Technical Manual.
- Failure to follow the instructions could cause personal injury or damage to the appliance or property. Only when installed, commissioned and serviced correctly, the appliance will offer you many years of trouble-free operation.
- The appliance is intended to 'soften' the water, meaning it will remove hardness minerals; it will not necessarily remove other contaminants present in the water. The appliance will not purify polluted water or make it safe to drink!
- Installation of the appliance should only be undertaken by a competent person, aware of the local codes in force. All plumbing and electrical connections must be done in accordance with local codes.
- Before setting up the appliance, make sure to check it for any externally visible damage; do not install or use when damaged.
- Use a hand truck to transport the appliance. To prevent accident or injury, do not hoist the appliance over your shoulder. Do not lay the appliance on its side.
- Keep this Technical Manual in a safe place and ensure that new users are familiar with the content.
- The appliance is designed and manufactured in accordance with current safety requirements and regulations. Incorrect repairs can result in unforeseen danger for the user, for which the manufacturer cannot be held responsible. Therefore repairs should only be undertaken by a competent technician, familiar and trained for this product.
- In respect of the environment, this appliance should be disposed of in accordance with Waste Electrical and Electronic Equipment requirements. Refer to national/local laws and codes for correct recycling of the appliance.

OPERATING CONDITIONS & REQUIREMENTS

- **OPERATING PRESSURE MIN-MAX: 1,4-5,0 bar / 20-73 psi**
 - for cold water applications (max. 48 °C (120 °F)) max. operating pressure is 8,3 bar (120 psi).
 - this appliance is configured to perform optimally at an operating pressure of 3 bar (45 psi) \pm ½ bar (7 psi); in case of a lower or higher operating pressure the performance may be affected negatively!
 - check water pressure regularly.
 - take into account that night time water pressure may be considerably higher than day time water pressure.
 - install a pressure reducer ahead of the appliance if necessary.

- **OPERATING TEMPERATURE MIN-MAX: 2-65 °C / 35-149 °F**
 - do not install the appliance in an environment where high ambient temperatures (e.g. unvented boiler house) or freezing temperatures can occur.
 - the appliance cannot be exposed to outdoor elements, such as direct sunlight or atmospheric precipitation.

- **ELECTRICAL CONNECTION:**
 - the appliance only works on 24 VDC; always use it in combination with the supplied transformer.
 - make sure to plug the transformer into a power outlet, which is installed in a dry location, with the proper rating and over-current protection.

INSTALLATION

PREPARATION BRINE CABINET

Picture 1&11

To facilitate the installation, you may want to remove the salt lid and main cover from the brine cabinet.

1. Remove the salt lid.
2. Unscrew the screw rivets at the front of the main cover.
3. Carefully lift the main cover from the water softener.

CASTER WHEELS (optional on micro & mini only)

In case the water softener is delivered with the optional caster wheel set, it needs to be mounted on the cabinet upon installation of the water softener.

Picture 2

1. Position the reinforcement plate on the bottom of the water softeners cabinet, making sure the 4 holes in the reinforcement plate align properly with the 4 threaded sockets in the cabinet.
2. Screw the 4 caster wheels into the threaded sockets; make sure to install the washers. Tighten firmly. Make sure the 2 caster wheels with brake are easily accessible.

INLET & OUTLET

In case of high concentration of impurities in the inlet water, we recommend the installation of a sediment filter, ahead of the appliance.

We strongly recommend the use of flexible hoses to connect the appliance to the water distribution system; use hoses with a large diameter in order to limit the pressure loss.

The inlet/outlet adaptors are equipped with an integrated non-return valve, to prevent any kind of backflow into the water softener or mains water supply; make sure to install them in the correct flow direction!

If the appliance is not equipped with the factory bypass (optional), we strongly recommend to install a 3-valve bypass system (not included with this product!) to isolate the appliance from the water distribution system in case of repairs. It allows to turn off the water to the appliance, while maintaining (untreated) water supply to the user.

WITH FACTORY BYPASS (optional)

Picture 3

❶ = mains water supply (untreated water)

❷ = inlet of appliance (untreated water)

❸ = outlet of appliance (treated water)

❹ = application (treated water)

1. Screw the factory bypass onto the elbow connections of the appliance (❷&❸); make sure to install the gasket seals. Tighten the nuts firmly by hand.
2. Screw the connection kit with nuts onto the factory bypass (❶&❹); make sure to install the gasket seals. Tighten the nuts firmly by hand.
3. Connect the mains water supply to the adaptor on the inlet port of the factory bypass (❶).
4. Connect the application to the adaptor on the outlet port of the factory bypass (❹).

WITH 3-VALVE BYPASS SYSTEM (not included)

Picture 4

❶ = inlet of appliance (untreated water)

❷ = outlet of appliance (treated water)

1. Install the 3-valve bypass system.
2. Screw the connection kit with nuts onto the elbow connections of the appliance (❶&❷); make sure to install the gasket seals. Tighten the nuts firmly by hand.
3. Connect the 3-valve bypass system to the adaptors on the in (❶) and out (❷) elbow connections.
4. Connect the mains water supply to the inlet of the 3-valve bypass system.
5. Connect the application to the outlet of the 3-valve bypass system.

DRAIN

We recommend the use of a stand pipe with P-trap.

To prevent backflow from the sewerage system into the appliance, always install and use the included drain adaptor with air gap and double hose barb, to connect the drain hoses to the sewerage system.

Always use separate drain hoses for the control valve (discharge of rinse water) and the brine cabinet's overflow.

Lay-out the drain hoses in such a way that pressure loss is minimized; avoid kinks and unnecessary elevations.

Make sure that the sewerage system is suitable for the rinse water flow rate of the appliance.

Picture 5

1. Install the drain adaptor to the sewerage system; it fits over a 32 mm pipe or inside a 40 mm pipe adaptor. Ensure a permanent and watertight connection.
2. Connect a 13 mm hose to the drain solenoid of the control valve (❶); secure it by means of a clamp.
3. Run the drain hose to the drain adaptor and connect it to one of the hose barbs; secure it by means of a clamp. This drain line operates under pressure, so it may be installed higher than the appliance.
4. Connect a 13 mm hose to the brine cabinet overflow elbow; secure it by means of a clamp.
5. Run the drain hose to the drain adaptor and connect it to the other hose barb; secure it by means of a clamp. This drain line does NOT operate under pressure, so it may NOT be installed higher than the appliance.

COMMISSIONING

ELECTRICAL

Picture 6

1. Plug the transformers output lead into the socket on the appliances power cord; secure it by means of the TwistLock clamp.
2. Plug the transformer into an electrical outlet.

PRESSURIZING

1. Make sure the bypass system is in 'bypass' position.
2. Make sure the electronic controller of the appliance is in service mode.
3. Open the mains water supply.
4. Open a cold treated water faucet nearby the appliance and let the water run for a few minutes until all air is purged and all foreign material that may have resulted from the installation is washed out; close the tap.
5. Gently pressurize the appliance, by putting it into service:
 - *factory bypass:*
 1. open the 'outlet' valve;
 2. slowly open the 'inlet' valve.
 - *3-valve bypass:*
 1. close the 'bypass' valve;
 2. open the 'outlet' valve;
 3. slowly open the 'inlet' valve.
6. After 2-3 minutes, open a cold treated water faucet nearby the appliance and let the water run for a few minutes until all air is purged from the installation and the resin bed is rinsed (it is normal for the rinse water to show some discoloration!); close the tap.
7. Check the appliance and all hydraulic connections for leaks.

After the first regenerations of the appliance, some slight discoloration of the treated water might occur. This is totally harmless and will disappear rapidly!

BRINE CABINET

1. Add water conditioner salt to the brine cabinet.

ELECTRONIC CONTROL PANEL

1. Program the electronic controller.

ADJUSTMENT RESIDUAL HARDNESS WITH FACTORY BYPASS (optional)

In practice the residual hardness is influenced by the inlet pressure, flow rate and hardness of the incoming untreated water. When adjusting the residual hardness, make sure these conditions are similar to the actual operating conditions.

Picture 7

1. Adjust the residual hardness of the water that leaves the appliance, by means of the adjusting screw, incorporated in the 'outlet' valve of the factory bypass:
 - to raise the residual hardness: turn the screw counter clockwise.

- to reduce the residual hardness: turn the screw clockwise.
2. Measure the residual water hardness with a water hardness test kit; readjust if necessary.

PERFORM REGENERATION

1. Manually initiate a regeneration, by pressing the *scroll*  button; the display will show:

Regen in 10 sec

2. Leave the appliance in this position; the countdown timer will countdown to 0 sec and start a regeneration.

ELECTRONIC CONTROL PANEL

Picture 8

symbol	button	function
	SCROLL	to advance to the next parameter
	UP	to increase the value of the parameter
	DOWN	to decrease the value of the parameter

POWER-UP

After power-up the display will show the 5-digit Part Number of the electronic board and the installed software version.

POWER FAILURE

In the event of a power failure, the program will remain stored in the NOVRAM® during an undefined period, while an incorporated SuperCap will maintain the correct time of day during a period of several hours; consequently, in case of prolonged power failure, the time of day might not be maintained; if this happens, the time of day will be reset to 8:00 when the power supply is re-established, while the indication will *flash*, indicating that the time of day needs to be set.

When the power failure occurs during the execution of an automatic regeneration, the appliance will immediately return to the service mode; when the power supply is re-established, the appliance will resume the regeneration.

TIMER FAILURE

In the event of a timer failure, the display will show the message:

Service Required

If powering off/on the appliance doesn't solve this problem, professional service is required.

MAINTENANCE REMINDER

Only available if the maintenance reminder function has been activated and programmed by your supplier!

Once the maintenance interval is reached, the display will intermittently show the message:

Maintenance Now

While the appliance will continue to operate normally, it is recommended to have preventive maintenance performed by a professional.

To reset the maintenance reminder, simply access the configuration parameters programming mode.

SERVICE MODE

In **service mode** the display shows the time of day and the remaining capacity:

8:01 1000L -

REGENERATION MODE

In **regeneration mode** the display shows the actual regeneration cycle and, where relevant, the total remaining regeneration time and remaining cycle time:

BRINE FILL

REGEN PENDING

Rgn:XXX CycY:ZZZ

*The appliance can be **reset to service mode** at any time by pressing the **scroll** button, as such manually advancing it through the regeneration cycles.*

CHECKING THE FLOW METER

In case of water usage, the remaining capacity counter in the service display will count back per unit, i.e. per litre. This way the correct functioning of the water meter can be verified.

MANUAL REGENERATION

It is possible to manually initiate an immediate regeneration or a delayed regeneration (at the preprogrammed time of regeneration).

1. Press the **scroll** button; the display will show:

Regen in 10 sec

- If the control panel is left in this position, the countdown timer will countdown to 0 sec and **start an immediate regeneration**.
- To cancel this mode, press the **scroll** button before the countdown timer has reached 0 sec; the display will show:

Regen @ 2:00

- If the control panel is left in this position, a **delayed regeneration will be started** at the indicated preprogrammed time of regeneration.
- To cancel this mode, press the **scroll** button; the control panel will return to the service mode.

ELECTRONIC CONTROL PANEL



PROGRAMMING INSTRUCTIONS - BASIC SETTINGS

Before entering the programming mode, make sure that the appliance is in service mode.



In case no button is pressed in a period of 5 min, the control panel will automatically return to the service mode; any changes made will NOT be saved!

1. Press the **scroll**  button and hold it for 2 sec until the display shows:



Language: English

- Press the **up**  or **down**  button to set the language.
2. Press the **scroll**  button again; the display will show:



Set time: 8:01

- Press the **up**  or **down**  button to set the time of day.
3. Press the **scroll**  button again; the display will show:

HardUnit: °f

- Press the **up**  or **down**  button to set the unit of measure for water hardness. Make sure it is identical to the unit of measure of the water hardness test kit or water analysis report that is used to determine the hardness of the incoming untreated water!
4. Press the **scroll**  button again; the display will show:

Set Hardn: XX °f

- Press the **up**  or **down**  button to set the hardness of the incoming untreated water.
5. Press the **scroll**  button again; the display will show:

Exit

- Press the **up**  or **down**  button to save the settings into the NOVRAM® and exit the programming mode.

PROGRAMMING INSTRUCTIONS - CONFIGURATION PARAMETERS

All configuration parameters on this appliance have been pre-programmed in the factory, to offer optimal performance in a wide range of applications and situations. See table at the end of this manual for default configuration parameter settings.

Before entering the programming mode, make sure that the appliance is in service mode.



In case no button is pressed in a period of 5 min, the control panel will automatically return to the service mode; any changes made will NOT be saved!

1. Press the **scroll**  button and hold it for 6 sec until the display shows:

System Check



2. Within 10 sec, press the **up**  button; the display will show:

Units: Metric

- Press the **up**  or **down**  button to set the units of measure (Metric or US).



3. Press the **scroll**  button again; the display will show:

MaintInt: OFF

- Press the **up**  or **down**  button to activate the maintenance reminder function by setting the maintenance interval, or deactivate the maintenance reminder function.

4. Press the **scroll**  button again; the display will show:

ExCap: 5.1 °f M3/L

- Press the **up**  or **down**  button to set the exchange capacity per litre of resin.

5. Press the **scroll**  button again; the display will show:

Resin: XXX liters

- Press the **up**  or **down**  button to set the volume of resin.

6. Press the **scroll**  button again; the display will show:

Override: 7 days

- Press the **up**  or **down**  button to set the number of days between regenerations.

7. Press the **scroll**  button again; the display will show:

Cycle 1: XXX sec

- Press the **up**  or **down**  button to set the length of the regeneration cycle.

ELECTRONIC CONTROL PANEL

- Press the **scroll** ⤴ button again to advance to the next regeneration cycle.

	Eco
Refill	Cycle 1
Brine preparation	Cycle 2
Brine draw/slow rinse	Cycle 3

8. Press the **scroll** ⤴ button again; the display will show:

Regen : Dlyd/Immd

- Press the **up** ▲ or **down** ▼ button to set the *regeneration mode*:
 - **Dlyd/Immd**: when the remaining capacity equals the reserve capacity, a *delayed regeneration* is started at the programmed time of regeneration; however when the remaining capacity equals 0 before the programmed time of regeneration is reached, an *immediate regeneration* is started.
 - **Immediate**: when the remaining capacity equals 0, an *immediate regeneration* is started.
 - **Delayed**: when the remaining capacity equals the reserve capacity, a *delayed regeneration* is started.

9. Press the **scroll** ⤴ button again; the display will show (only when the regeneration mode was set to 'Delayed' or 'Dlyd/Immd'):

Regen @ 2:00

- Press the **up** ▲ or **down** ▼ button to set the *time of regeneration*.

10. Press the **scroll** ⤴ button again; the display will show (only when the regeneration mode was set to 'Dlyd' or 'Dlyd/Immd'):

Rsrv Variable

- Press the **up** ▲ or **down** ▼ button to set the *reserve capacity*:
 - **Variable**: the reserve capacity is calculated automatically, based on the registered daily water usage.
 - **Fxd**: press the **scroll** ⤴ button again and press the **up** ▲ or **down** ▼ button to set the *reserve capacity to a fixed amount*.

11. Press the **scroll** ⤴ button again; the display will show:

AUX: Regen

- Press the **up** ▲ or **down** ▼ button to set the *function of the auxiliary contact*:
 - **Regen**: aux. contact is powered during entire regeneration (does not include refill and brine preparation cycles!).
 - **Chlor.Cell**: aux. contact is powered at start of brine draw/slow rinse cycle. Press the **scroll** ⤴ button again and press the **up** ▲ or **down** ▼ button to set the *duration of activation of the chlorination cell*.
 - **Maintenance**: aux. contact is powered when maintenance reminder is triggered.

- **Error**: aux. contact is powered when timer failure occurs.

12. Press the **scroll** ⤴ button again; the display will show:

Exit

- Press the **up** ▲ or **down** ▼ button to save the settings into the NOVRAM® and exit the programming mode.

ELECTRONIC CONTROL PANEL

DIAGNOSTICS MODE

- ☑ *In the Diagnostics mode several operating parameters can be consulted; particularly during a service intervention, these parameters can be helpful to identify the cause of a problem or malfunction.*
- ☑ *Before entering the Diagnostics mode, make sure that the appliance is in service mode.*
- ☑ *In case no button is pressed in a period of 5 min, the control panel will automatically return to the service mode!*

ACCESSING THE DIAGNOSTICS MODE

1. Press the **scroll** ⤴ button and hold it for 6 sec until the display shows:

System Check

2. Within 10 sec, press the **down** ⬇ button; the display will show:

Regen XXdays ago

- You are now in the Diagnostics mode.
- Press the **scroll** ⤴ button to advance to the next diagnostics parameter.

AVAILABLE DIAGNOSTICS PARAMETERS

- **Regen X days ago**: number of days since last regeneration.
- **In Srvc**: total number of days in service.
- **# of Regens**: number of regenerations since installation.
- **TotVol**: total volume of treated water since installation.
- **LastSet**: number of days since last change of configuration parameter or hardness of incoming untreated water.
- **InstFlow**: instantaneous flow rate through appliance.
- **AvgVol**: calculated average daily water usage.
- **LastRgn@**: consumed capacity at last regeneration.
- **Capacity**: calculated capacity between regenerations.
- **MaintCnt**: current status of maintenance reminder counter (counting up).
- **MP Resets**: number of resets of microprocessor.
- **Memory Reset**: number of corrupt memory start-ups.
- **CapToUse**: remaining capacity.
- **Fill**: length of refill cycle of last regeneration.
- **Reserve**: calculated reserve capacity.
- **EZ3P5f EZ3PB r14**: software version.

EXITING THE DIAGNOSTICS MODE

1. Press the **scroll** ⤴ button repeatedly until the display shows:

Exit

- Press the **up** ⬆ or **down** ⬇ button to exit the Diagnostics mode.

MAINTENANCE

RECOMMENDATION

Notwithstanding the reliability of the appliance, we strongly recommend to have it serviced and maintained on a regular basis by a competent and duly trained technician. He will be able to determine the appropriate maintenance interval for the appliance, depending on your specific application and the local operating conditions. The advantages of performing regular maintenance are:

- regular check of the local operating conditions (water quality, pressure, etc);
- regular control and adjustment of the settings of the appliance, to guarantee it operates at maximum efficiency;
- minimize the risk of unexpected break-down.

Contact your dealer or installer for more information, or visit our website.

ROUTINE CHECKS

Regularly the user should perform a basic check to verify if the appliance is functioning correctly, on the basis of the following control points:

1. Check settings of electronic control panel.
2. Measure water hardness before/after appliance.
3. Check drain line from control valve; there shouldn't be any water flow (unless appliance is in regeneration).
4. Check drain line from brine cabinet overflow; there shouldn't be any water flow.
5. Check appliance and surrounding area; there shouldn't be any water leakages.

BYPASSING THE APPLIANCE

Occasionally it may be necessary to put the appliance hydraulically in bypass, i.e. to isolate it from the water distribution system; f.e.:

- in case of an urgent technical problem;
- when it is not necessary to supply treated water to the house/application (refill swimming pool, irrigation,...).

WITH FACTORY BYPASS (optional)

Picture 9.a

SERVICE POSITION

- ❶ = inlet valve to appliance is OPEN
- ❷ = outlet valve from appliance is OPEN

Picture 9.b

BYPASS POSITION

- ❶ = inlet valve to appliance is CLOSED
- ❷ = outlet valve from appliance is CLOSED

Picture 9.c

MAINTENANCE POSITION

- ❶ = inlet valve to appliance is OPEN
- ❷ = outlet valve from appliance is CLOSED

WITH 3-VALVE BYPASS SYSTEM (not included)

Picture 10.a

SERVICE POSITION

- ❶ = bypass valve is CLOSED
- ❷ = inlet valve to appliance is OPEN
- ❸ = outlet valve from appliance is OPEN

Picture 10.b

BYPASS POSITION

- ❶ = bypass valve is OPEN
- ❷ = inlet valve to appliance is CLOSED
- ❸ = outlet valve from appliance is CLOSED

Picture 10.c

MAINTENANCE POSITION

- ❶ = bypass valve is OPEN
- ❷ = inlet valve to appliance is OPEN
- ❸ = outlet valve from appliance is CLOSED

WATER CONDITIONER SALT

Picture 11

The appliance needs 'brine' for its periodic regenerations. This brine solution is made from water, that is automatically dosed in the brine cabinet by the control valve, and water conditioner salt. The user should make sure that the brine cabinet is always kept full of water conditioner salt. Therefore he should periodically check the salt level inside the brine cabinet and refill it if necessary. The salt lid can be removed completely to facilitate refilling.

Ideally the level of water conditioner salt inside the brine cabinet is kept between 1/3 and 2/3. A lower level of water conditioner salt can cause insufficient brine saturation, resulting in a loss of softening capacity. A higher level of water conditioner salt can cause salt bridging (hard crust or salt bridges in the brine cabinet). When you suspect salt bridging:

- carefully pound on the outside of the brine cabinet to break loose the salt bridges;
- using a broom (or like blunt tool) carefully push the salt to break it apart;
- pour warm water over the top of the salt to dissolve it.

APPEARANCE

To retain the appearance of the appliance, simply wipe it with a damp cloth or clean it with a mild soap solution; never use abrasive cleaners, ammonia or solvents.

RESIN CLEANER

Other contaminants (f.e. iron) present in the feed water can cause the resin bed to foul up, resulting in a loss of softening capacity. An approved resin cleaner can be used periodically to thoroughly clean the resin bed.

SANITIZING THE APPLIANCE

This appliance is manufactured from premium quality material and assembled in safe conditions to assure it is clean and sanitary. If installed and serviced correctly, this appliance will not infect or contaminate your water supply. However, as in any 'device' plumbed-in in your water distribution system, a proliferation of bacteria is possible, especially in case of 'stagnant water'. Therefore this appliance is equipped with a 'days override' feature, that will automatically rinse the resin bed periodically, even in case of low or absence of water usage.

If the power supply to the appliance is disconnected for a longer period of time, we recommend, when the power supply is re-established, to manually initiate a complete regeneration.

HYDRAULIC FLOW DIAGRAMS

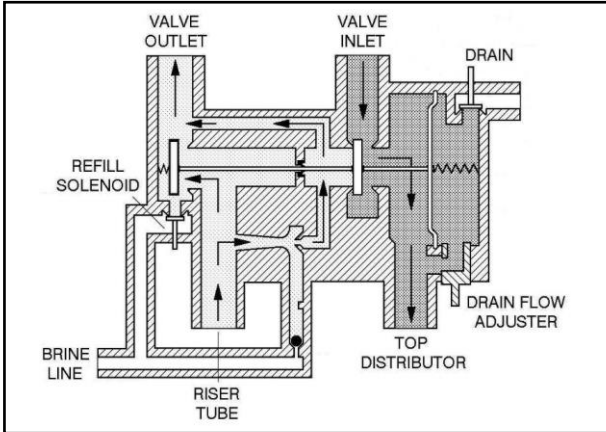
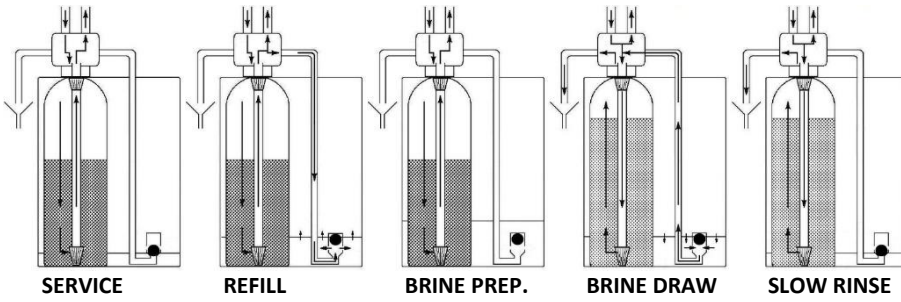

SERVICE

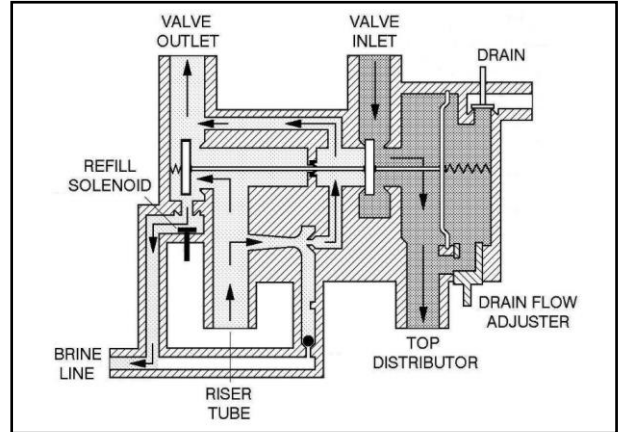

REFILL

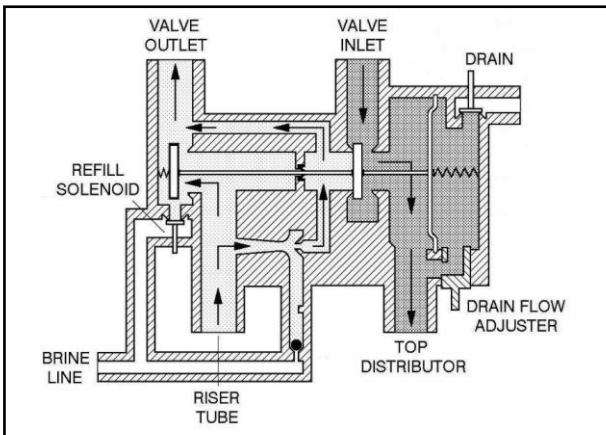

BRINE PREPARATION

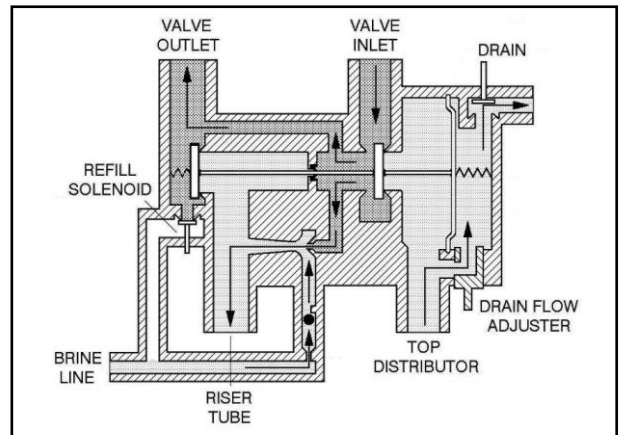

BRINE DRAW / SLOW RINSE

TROUBLESHOOTING

PROBLEM	CAUSE	SOLUTION
Hard (untreated) water to service	Open or defective bypass	Close or replace bypass
	Appliance in regeneration	Wait until regeneration finishes or manually advance regeneration to end
	No salt in brine cabinet	Add salt and initiate regeneration manually
	Salt bridging	Break salt bridge(s) and initiate regeneration manually
	Change in raw water hardness	Measure the hardness of the incoming untreated water and adjust programming accordingly
	Appliance fails to regenerate	Refer to problem "Appliance fails to regenerate"
	Improper brine draw	Refer to problem "Improper brine draw"
	Decreasing exchange capacity of resin	Clean or replace resin bed
	Loss of resin	Refer to problem "Loss of resin"
Leak at riser tube	Verify that riser tube is seated correctly and is not cracked	
Residual hardness in treated water	Bypass not completely closed	Close bypass
	Appliance is overrunning its softening capacity	Measure the hardness of the incoming untreated water and adjust programming accordingly
		Verify operation of flow meter
Appliance fails to regenerate	Faulty electrical supply	Verify electrical service (fuse, transformer,...)
	Defective flow meter	Verify operation of flow meter
	Defective PCB	Replace PCB
	Defective drain solenoid	Replace drain solenoid
	Control valve does not switch to regeneration position	Check operating pressure; must be higher than 1,4 bar
Appliance uses too much salt	Excessive water in brine cabinet	Refer to problem "Excessive water in brine cabinet"
	System regenerates too frequently	Measure the hardness of the incoming untreated water and adjust programming accordingly
Excessive water in brine cabinet	Improper brine draw	Refer to problem "Improper brine draw"
	Improper setting of refill cycle	Verify setting of refill cycle
	Missing refill flow control	Verify that refill flow control is installed and properly sized
	Leak from control valve to brine cabinet	Clean or replace plunger and solenoid diaphragm of refill solenoid
		Check seal between brine draw check ball and brine draw restrictor
Salt taste in treated water	Improper setting of brine draw/slow rinse cycle	Verify setting of brine draw/slow rinse cycle
	Excessive water in brine tank	Refer to problem "Excessive water in brine tank"
	Improper brine draw	Refer to problem "Improper brine draw"
Loss of water pressure	Mineral or iron build-up in resin tank	Clean resin bed and control valve; increase regeneration frequency
	Plugged lower and/or upper distributor	Verify that distributors are free of debris
	Crushed lower and/or upper distributor	Replace distributor(s)
Drain line from control valve flows continuously	Appliance in regeneration	Wait until regeneration finishes or manually advance regeneration to end
	Drain solenoid stuck in open position	Clean drain solenoid
	Defective PCB	Replace PCB
Drain line from brine cabinet overflow flows continuously	Excessive water in brine cabinet	Refer to problem "Excessive water in brine cabinet"
	Leak between control valve and pressure tank	Verify seal between control valve and pressure tank
Control valve fails to refill brine tank	Improper setting of refill cycle	Verify setting of refill cycle
	Plugged refill flow control	Clean refill flow control
	Refill solenoid not opening	Verify operation of refill solenoid
Loss of resin	Lower and/or upper distributor damaged	Replace distributor(s)
	Leak between riser tube and upper distributor	Verify that riser tube is seated correctly and is not cracked

TROUBLESHOOTING

PROBLEM	CAUSE	SOLUTION
Improper brine draw	Low operating pressure	Check operating pressure; must be higher than 1,4 bar
	Plugged injector and/or brine draw restrictor	Clean injector and/or brine draw restrictor
	Plugged injector filter	Clean injector filter
	Restricted drain line	Verify drain line for kinks or restrictions
	Restricted brine line	Verify brine line for kinks or restrictions
	Leak in brine line	Verify brine line and connections for air leakage
	No water in brine tank	Refer to problem "Control valve fails to refill brine tank"

ELECTRICAL WIRING DIAGRAM

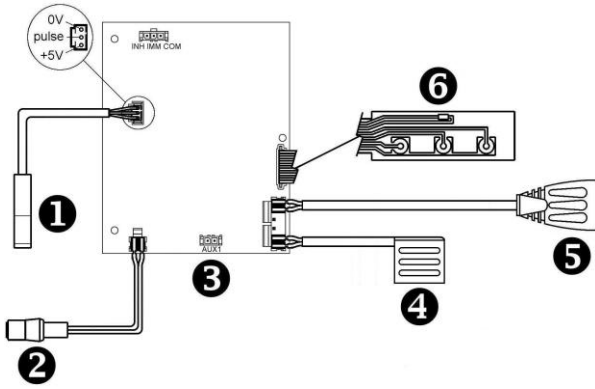

- ❶ = flow meter
- ❷ = power lead
- ❸ = auxilliary contact (24 VDC, max. 500mA)
- ❹ = refill solenoid, marked with RF
- ❺ = drain solenoid
- ❻ = key pad

DEFAULT CONFIGURATION PARAMETER SETTINGS

Model	H2O-CS-Eco-			
	9	12	18	26
Resin				
Units	Metric	Metric	Metric	Metric
MaintInt (mths)	OFF	OFF	OFF	OFF
Exchange capacity per liter resin (°f M ³ /L) ^{(1) (2)}	3,5	4,0	4,5	4,5
Resin (liters)	9	12	18	26
Override (days)	7	7	7	7
Cycle 1: REFILL (sec) ⁽²⁾	198	264	396	572
Cycle 2: BRINE PREPARATION (min)	15	15	15	15
Cycle 3: BRINE DRAW/SLOW RINSE (min)	45	50	75	110
Regen	Dlyd/Immd	Dlyd/Immd	Dlyd/Immd	Dlyd/Immd
Regen @	2:00	2:00	2:00	2:00
Rsrv	Variable	Variable	Variable	Variable
Auxiliary contact	Regen	Regen	Regen	Regen

(1) When the Hardness Unit is changed in the Basic Settings, the Exchange capacity per liter resin is automatically converted to the new Hardness Unit.

(2) When the Exchange capacity per liter resin is changed, the refill cycle time needs to be adjusted accordingly.

EXPLODED VIEW - SYSTEM

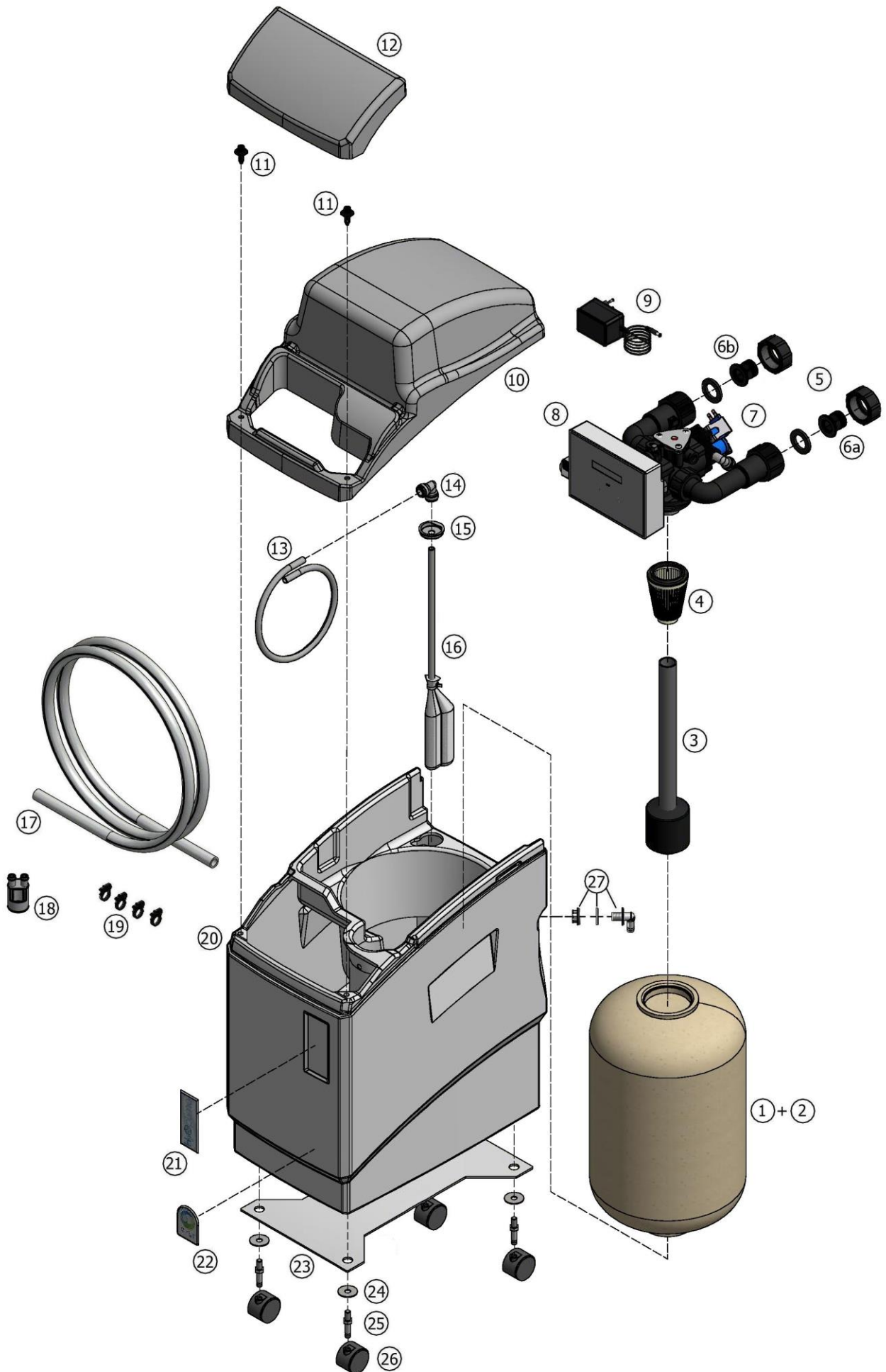

EXPLODED VIEW - SYSTEM

Item	PN	Description	Remark	(*)
1	PT/0913/CP	Pressure tank 9x13	9L	✓
	PT/0916/CP	Pressure tank 9x16	12L	✓
	PT/0922/CP	Pressure tank 9x22	18L	✓
	PT/0932/CP	Pressure tank 9x32	26L	✓
2	E8000	Softening resin		✓
3	38528	Riser tube assembly with deflector	to be cut to length	✓
4	287/166	Top distributor		✓
5	568/232	Nut, connection kit (2x)		✓
6a	39078	Inlet adaptor ¾" BSP male plastic, with check valve		✓
6b	39079	Outlet adaptor ¾" BSP male plastic, with check valve		✓
7	71110	Gasket, connection kit (2x)		✓
8	541N89/J90	Control valve assembly	9L	✓
	541N89/J80	Control valve assembly	12L, 18L, 26L	✓
9	74312	Transformer 230/24VDC - 50 Hz, 24VA, EuroT plug		✓
10	39040	Cover		
11	38547	Screw rivet (2x)		✓
12	39041	Salt lid		✓
13	H1015/2	Brine line polytube	to be ordered per meter	✓
14	DM/A6EU6	Quick-fit elbow 3/8"		✓
15	38560	Plastic cap		
16	74269	Air check assembly	to be cut to length	✓
17	38522	Drain hose	to be ordered per meter	
18	74163	Air gap with double hose barb		
19	74174	Clamp, drain hose (4x)		
20	39009	Cabinet body, micro	9L	
	39080	Cabinet body, mini	12L	
	39011	Cabinet body, midi	18L	
	39012	Cabinet body, maxi	26L	
21	39054	Dome label 'H2Optimo'		
22	39004	Dome label 'erie water treatment'		
23	39076	Aluminum cabinet support	only for 9L, 12L	
24	39075	Washer M8x30 (x4)	only for 9L, 12L	
25	39073	Mounting pin, swivel caster (x4)	only for 9L, 12L	
26	39072	Swivel caster, without brake (x2)	only for 9L, 12L	✓
	39071	Swivel caster, with brake (x2)	only for 9L, 12L	✓
27	38532	Overflow assembly		

(*) Recommended Spare Part

EXPLODED VIEW - VALVE BODY ASSEMBLY

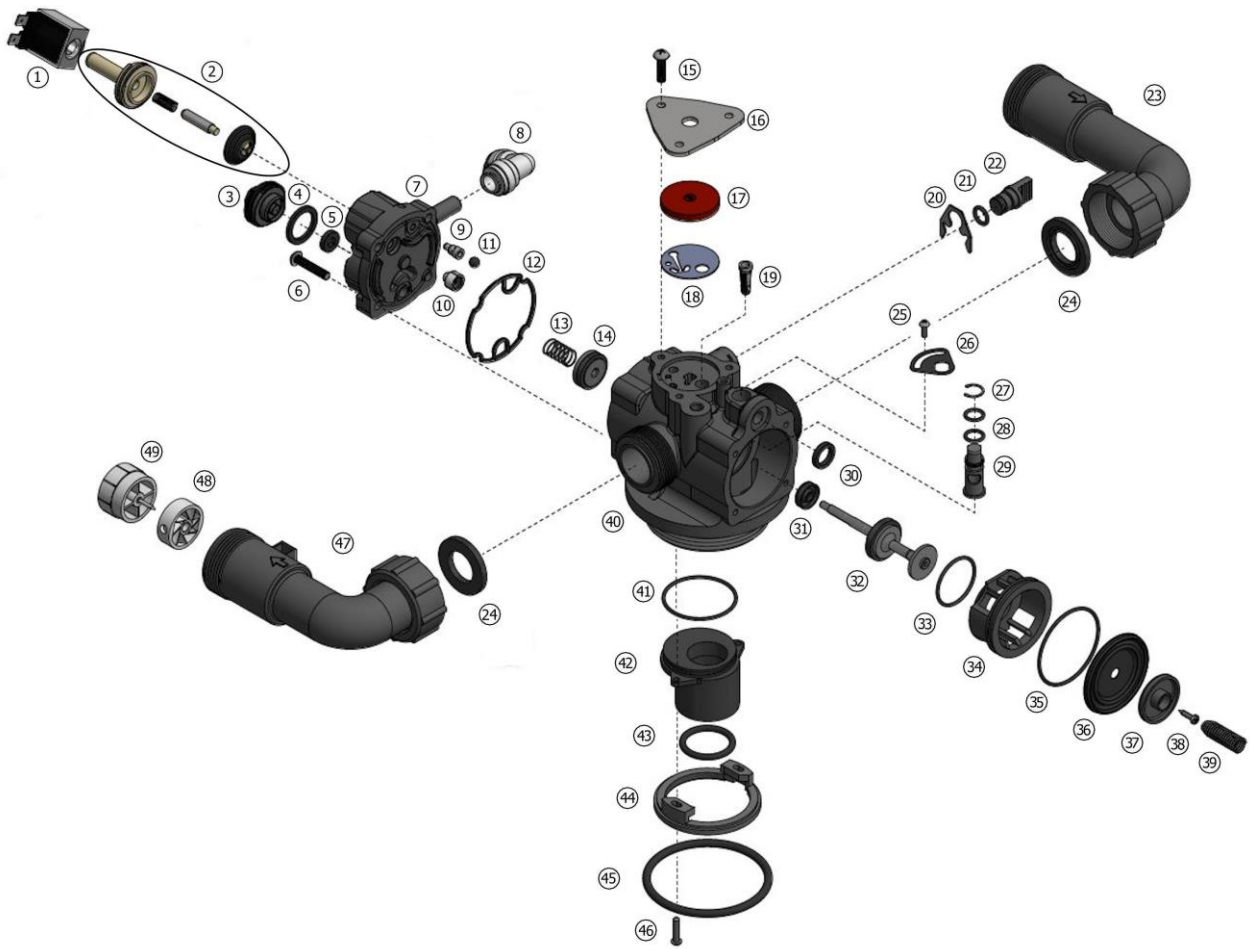

EXPLODED VIEW - VALVE BODY ASSEMBLY

Item	PN	Description	Remark	(*)
1	74345	Solenoid		✓
2	74346	Solenoid plunger assembly: <ul style="list-style-type: none"> • Guide, solenoid • Spring, solenoid plunger • Plunger, solenoid • Diaphragm, solenoid 	Only available as assy	✓
3	74283	Back cap plug		✓
4	74324	Seal, back cap plug (large)		
5	74323	Seal, back cap plug (small)		
6	15/222	Screw, back cap (4x)		✓
7	74306	Back cap		✓
8	74258	Brine elbow		
9	74022	Brine draw restrictor 1,0 mm (black)		
10	568/385/2/A	Refill flow control 0,25 gpm		
11	541/275	Check ball		✓
12	541/206	Gasket, back cap		
13	541/239	Spring, check disc	Repair kit A	
14	541/246	Check disc	Repair kit A	
15	15/89	Screw, cover plate (3x)		
16	541/221	Cover plate, injector		
17	428/5	Injector disc #5		✓
18	541/325	Gasket, injector		✓
19	74179	Filter, injector		✓
20	541/254	Spring clip		
21	186/118	O-ring, brine plug		
22	541/273	Brine plug		
23	72542	Elbow, inlet		
24	72467	Union gasket (2x)		
25	15/76	Screw, locking plate		
26	72609	Locking plate, drain flow adjuster		
27	19/19	Clip, drain flow adjuster		
28	186/134	O-ring, drain flow adjuster (2x)		
29	541/238	Drain flow adjuster		
30	529/244	O-ring, drain port		
31	467/216	Seal, body stem	Repair kit A	✓
32	72605	Body stem	Repair kit A – Repair kit B	
33	185/024/1	O-ring, seat insert (small)	Repair kit A	
34	541/204	Seat insert	Repair kit A	✓
35	185/029/1	O-ring, seat insert (large)	Repair kit A	
36	72602	Main diaphragm	Repair kit A – Repair kit B	✓
37	72507	Retainer, main diaphragm	Repair kit A – Repair kit B	
38	72552	Screw, main diaphragm	Repair kit A – Repair kit B	✓
39	516/221	Spring, main diaphragm	Repair kit A	
40	541/257/1	Valve body (incl. 467/216)		
41	185/029/1	O-ring, riser insert		
42	541/218	Riser insert 1,050"		
43	185/214/1	O-ring, riser tube		
44	541/232	Adapter ring		
45	185/67/4	O-ring, tank		
46	15/90	Screw, adapter ring (2x)		
47	72543	Elbow, outlet		
48	72544	Impeller		✓
49	72545	Hub, impeller		
A	RK/541/244	Repair kit body stem and seat		✓
B	72611	Repair kit body stem		✓

(*) Recommended Spare Part

EXPLODED VIEW - VALVE HEAD & TIMER ASSEMBLY

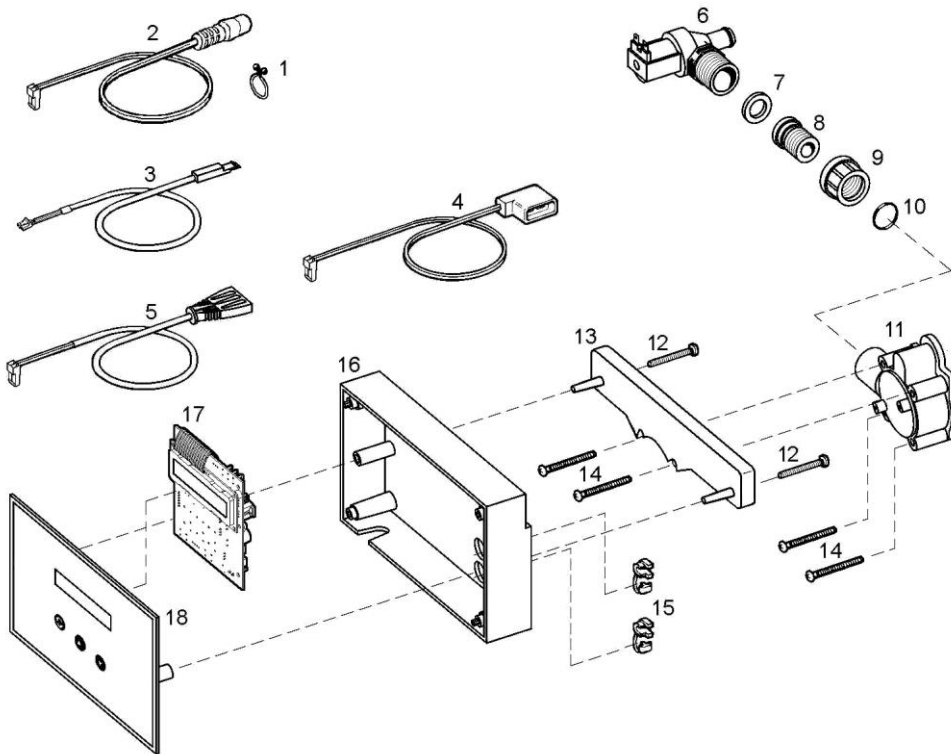

Item	PN	Description	Remark	(*)
1	72263	Twist lock clamp, power cord		
2	74307	Power cord		✓
3	72519	Flow meter cable		✓
4	74340	Refill solenoid cable		✓
5	72561	Drain solenoid cable		✓
6	74023	Drain solenoid		✓
7	74019	Gasket, drain solenoid		
8	74016	Drain line adaptor		
9	74018	Nut, drain solenoid		
10	185/115/1	O-ring, drain line adaptor		
11	15/87	Screw, valve head (4x)		
12	72216	Valve head		
13	74262	Screw, timer housing (2x)	Standard metric thread (ISO)	
14	74189	Timer mounting bracket		
15	28/8/28	Strain relief (2x)		
16	74026	PCB housing back		
17	74315	Printed Circuit Board, 24VDC		✓
18	74230	PCB housing front assembly	Standard metric thread (ISO)	✓

(*) Recommended Spare Part

TECHNICAL DATA

Technical specifications:

Model	H2O-CS-Eco-			
Resin (Ltr)	9	12	18	26
Operating pressure min/max (bar) ⁽¹⁾	1,4/5,0			
Operating temperature min/max (°C) ⁽¹⁾	2/65			
Electrical connection (V/Hz)	230/50 ⁽²⁾			
Maximum power consumption (VA)	4.7			
Hydraulic connection inlet/outlet	¾" BSP Male			

(1) For cold water applications (max. 48 °C) max. operating pressure is 8,3 bar

(2) Supplied with 24V transformer

Performances @ 3 bar operating pressure ⁽³⁾:

Model	H2O-CS-Eco-			
Resin (Ltr)	9	12	18	26
Nominal exchange capacity (m ³ x°f)	32	48	81	117
Nominal exchange capacity (m ³ x°d)	18	26	45	65
Service flow rate @Δp 1 bar (m ³ /hr)	1,6	1,6	1,5	1,4
Recommended maximum service flow (m ³ /hr) ⁽⁴⁾	0,9	1,2	1,8	2,6
Salt usage per regeneration (kg) ⁽⁵⁾	1,1	1,5	2,3	3,3
Rinse water usage per regeneration (Ltr) ⁽⁵⁾	49	54	82	120

(3) Indicative numbers, performances depending on operating conditions and water quality

(4) Flow rate at which softening process is still executed adequately

(5) Maximum salt/water usage as brining is proportional (minimum of 60%)

Dimensions & weights:

Model	H2O-CS-Eco-			
Resin (Ltr)	9	12	18	26
Width (mm) (W)	280			
Height (mm) (H1)	513	591	744	998
Height, including wheels (mm) (H2)	567	645	N/A	N/A
Depth (mm) (D)	438			
Depth, including bypass (mm)	540			
Height inlet/outlet (mm)	375	453	606	860
Height inlet/outlet, including bypass (mm)	381	459	612	866
Weight (kg)	15,5	20,0	26,5	36,0
Weight, including bypass (kg)	16,0	20,5	27,0	36,5
Maximum salt storage capacity (kg)	13	17	23	35

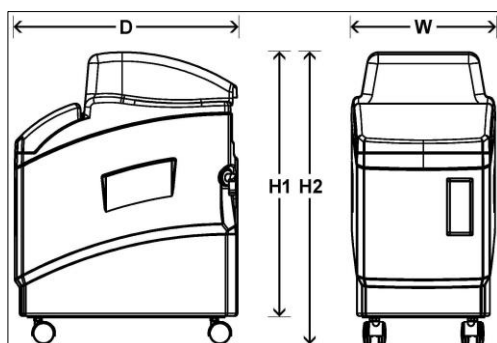



erie water treatment

a division of **Aquion, Inc.**

www.eriwatertreatment.com